

2014

Collezione Ufficio

Office Collection

オフィスコレクション

办公家具系列

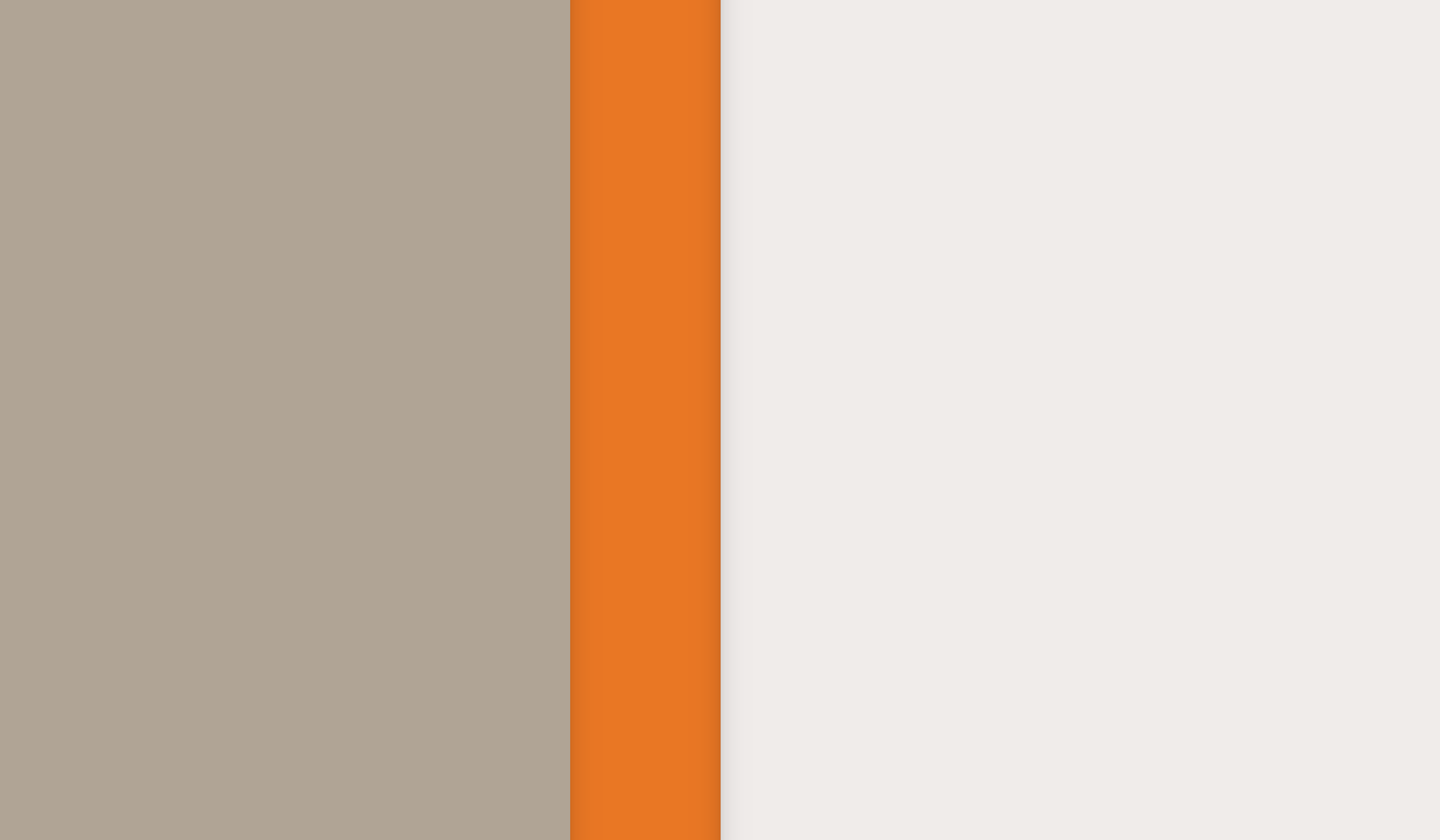



2014

Collezione Ufficio
Office Collection
オフィスコレクション
办公家具系列

2014 Office Collection Index

SISTEMI DIREZIONALI
C.E.O. OFFICE FURNITURE
エグゼクティブ システムズ
扶椅办公室

06 Jobs
→ Rodolfo Dordoni

POLTRONE UFFICIO
OFFICE ARMCHAIRS
オフィス用アームチェア
领导体系

36 DownTown
→ Jean-Marie Massaud

44 Ginger Ale Office
→ Roberto Lazzeroni

COLOR SYSTEM FRAU®
COLOR SYSTEM FRAU®
カラーシステムフラウレザー®
SC 皮革系列

52 Pelle Frau®
→ Color System Frau®

Rodolfo Dordoni

Jobs



RODOLFO DORDONI

Architetto e Designer, nasce e si laurea a Milano. Responsabile nel corso degli anni della direzione artistica di prestigiosi brand del design, disegna prodotti per numerose aziende. Dordoni Architetti, studio fondato a Milano da Rodolfo Dordoni, Luca Zaniboni e Alessandro Acerbi, opera nel campo dell'architettura e dell'interior design in ambito residenziale, commerciale ed allestitivo, sviluppando progetti di ville e abitazioni private, spazi industriali e commerciali curando la realizzazione di showrooms, stand espositivi, ristoranti, hotels.

CONCEPT

Jobs esprime in se e nel suo nome l'atto conclusivo di un percorso progettuale innovativo. Il nuovo sistema d'arredo direzionale nasce da un'attenta riflessione sull'evoluzione dei comportamenti in relazione alle nuove tecnologie e da un'accurata selezione dei materiali: pelle, legni lucidi ed opachi e strutture in metallo spazzolato arricchiscono in tono sobrio ed essenziale i differenti volumi e determinano nuove aree di lavoro.

ロドルフォ・ドルドーニ

建築家・デザイナー。ミラノ生まれ、同地で大学卒業。一流デザインブランドのアートディレクションの責任者として、多数の企業向けにデザインを手掛ける。Rodolfo Dordoni、Luca Zaniboni ルカ・ザニボニ）、Alessandro Acerbi（アレッサンドロ・アチエルビ）がミラノに開いた建築事務所、Dordoni Architetti（ドルドーニ・アルキテッティ）は、住居、商業、展示に関連する建築・インテリアデザインの分野で活動。個人の邸宅や住宅、商業

RODOLFO DORDONI

Architect and designer, Rodolfo Dordoni was born in Milan where He graduated. Responsible over the years for the art direction of numerous prestigious design brands, he has worked for many companies. Dordoni Architetti, a studio founded in Milan by Rodolfo Dordoni, Luca Zaniboni and Alessandro Acerbi, works in the field of architectural planning and interior design in the residential, commercial and exhibition areas, designing projects for private houses and villas, industrial and commercial spaces, and overseeing the realisation of showrooms, exhibition stands, restaurants, and hotels.

CONCEPT

Jobs expresses in itself and its name the final act of an innovative design path. The new managerial system has been created through careful reflection on the evolution of behaviours in relationship to new technologies and through the careful selection of materials. Leather, polished and matte woods and brushed metal structures give a sober and essential feel to the different volumes and determine new work areas.

施設や産業施設のプロジェクトを実現する一方、ショールーム、展示会のスタンド、レストラン、ホテルなどの企画も手掛けている。

コンセプト

Jobs はそれ自身、そしてその名前自体に、革新的で計画的な工程を踏むという明確な行為を表現しています。新たなエグゼクティブ システムは、新しいテクノロジーとの関係の中で起こる行動の変化についての慎重な考察と、注意深い素材の選択から生まれました。レザー、ポリッシュ加工とマット加工の木材、ブラッシュドメタル構造が、控えめに本質的なトーンの中にも多様なボリュームを生み出し新しい仕事の領域を切り開いています。

罗多尔夫·多尔多尼

建筑师及设计师，他出生于米兰，毕业于米兰理工大学建筑专业，多年来为很多知名设计品牌担任艺术指导。多尔多尼建筑事务所由罗多尔夫·多尔多尼、卢卡·扎尼波尼 Luca Zaniboni 和 阿雷桑德罗·阿切尔比 Alessandro Acerbi 创建于米兰，主要从事住宅、商业及展览领域内的室内设计及建筑业务，同时负责私人住宅和别墅，工商业空间的项目设计，监督展厅，展馆，餐厅以及酒店等项目的实施完成。

理念

Jobs 系列以其命名表达了其在创新性设计领域之路的探索。通过仔细反思人类行为的进化关系和对材质的精挑细选，创造出了新的管理系统。通过对不同体积产品之上皮革，亮光饰面，哑光饰面以及拉丝金属结构的运用，创造出一个全新的理性却不可或缺的一种感觉。









Jobs Materials

Armonia di materiali: pelle, rovere, acciaio.
Alternanza di superfici lucide e opache. Una combinazione di texture da applicare sui diversi elementi che compongono il sistema
Jobs: strutture portanti, basi, colonne passacavi, fessure per l'uscita dei cavi, mobili e cassettiere, "Guest area", "Meeting area".

ACCIAIO SATINATO VERNICIATO PIOMBO

La struttura delle scrivanie con caratteristica sezione a "T" e la base dei cabinet sono in acciaio satinato verniciato piombo.

ROVERE PIOMBO E ROVERE TABACCO

Due differenti colori di rovere, nelle finiture lucido ed opaco. Opaco per la "Guest area" e la "Meeting area", lucido per la colonna passacavi di Easy Desk ed Executive Desk. In Rovere opaco, Piombo o Tabacco, è anche la fascia in legno che corre su tutta la lunghezza del piano e separa l'area di lavoro dalla "Guest area" consentendo, grazie ad una fessura nascosta nel legno, l'uscita dei cavi elettrici. Mobili e cassettiere, impiallacciati in Rovere Piombo o Tabacco, abbinano finiture lucide e opache.

PELLE FRAU® COLOR SYSTEM

96 differenti nuance del Color System Frau®. 96 possibili colori di pelle con cui rivestire l'area di lavoro del piano delle scrivanie e i frontali dei cassetti di cassettiere e cabinet. Anche la "Guest area", a richiesta, può essere rivestita in pelle come il resto del piano.

Harmony of materials: leather, Oakwood and steel. Alternating polished and matte surfaces. A combination of textures to apply to the different elements that make up the Jobs system: supporting frames, bases, cable management columns, cable outlet slots, cabinets and chests of drawers, "Guest area", and "Meeting area".

BRUSHED STEEL WITH A LEAD PAINTED FINISH

The structure of the desks with characteristic T-section and the base of the cabinets are in brushed steel with a lead painted finish.

LEAD OAKWOOD AND TOBACCO OAKWOOD

Two different colours of Oakwood, with polished and matte finishes. Matte for the guest area and the "Meeting area", and polished for the cable management columns of the Easy Desk and Executive Desk. A matte-finish oak strip in Lead or Tobacco runs the entire length of the top and separates the work area from the "Guest area". The electrical cables come out through a hidden slot in the wood. Cabinets and chests of drawers are oak veneered in Lead or Tobacco with glossy and matte finishes.

PELLE FRAU® COLOR SYSTEM

Color System Frau® offers 96 different shades. 96 possible leather colours for upholstering desk work Tops and drawer fronts. On request, the "Guest area" can also be upholstered in leather like the rest of the top.

素材の調和: レザー、オーク、スチールポリッシュ加工とマット加工の組み合わせ Jobs システムを構成する複数の要素として採用されるテクスチャーのコンビネーション: 耐力構造、台、ケーブルモール、ケーブル用の溝、家具や引き出し、"Guest area" (ゲストエリア)、"Meeting area" (ミーティングエリア)

PIOMBO 鉛色のサテン仕上げスチール

デスクの構造は、断面が特徴的な "T" で、キャビネットの台は Piombo 鉛色のサテン仕上げスチール。

PIOMBO 鉛色オークと TABACCO 黄褐色オーク

オークには2色あり、ポリッシュ加工もしくはマット加工が施されています。マット加工は "Guest area" (ゲストエリア) と "Meeting area" (ミーティングエリア) に、ポリッシュ加工は Easy Desk (イージー・デスク) と Executive Desk (エグゼクティブ・デスク) のケーブルホールに使用。作業台の長さにあわせた "Guest area" と仕事場の境界となる木製の平縁は、Piombo もしくは Tabacco のマット仕上げオークで、木材の内に隠してある溝を通して電気配線を取ることが可能です。引き出しの筐体とキャビネットは Piombo もしくは Tabacco のオークで合板張りされ、ポリッシュ加工もしくはマット加工が施されます。

PELLE FRAU® COLOR SYSTEM ペッレフラウ®のカラーシステム

カラーシステムフラウレザー® Color System Frau® (カラーシステムフラウレザー®) の 96 種類の異なるニュアンス。デスク平面部の作業台や、チェストとキャビネットの引き出しの正面部分を覆うレザーの色に 96 つの可能な選択肢があります。"Guest area" (ゲストエリア) も、要望があれば、卓上の他の部分と同じレザーにすることが可能。

皮革、橡木和钢铁等材质的和谐运用。亮光饰面和哑光饰面的交替使用。支撑框架，底座，电缆内部管道，电缆出口槽，柜子，边桌，以及会客区块和会议区块等不同部位，不同材质，不同元素的组合运用。

钢制含铅涂层饰面

T形书桌框架以及柜子底部采用钢制含铅涂层饰

面。i 铅色橡木和烟草色橡木

两种不同颜色的橡木，有亮光和哑光两种不同饰面可选，哑光饰面主要用于会客区块和会议区块，亮光饰面主要用于电缆管理管道以及简易桌和大班桌。一条哑光浅色或者烟草色饰面的橡木板条把工作区块和会客区块分隔开来。电缆线通过一个隐藏的木质槽口走出。

PELLE FRAU® 专利皮革 SC 系列

Pelle Frau® SC 系列皮革共有 96 种不同的色彩，可用于书桌台面以及抽屉面板的软包。会客区块选用同面板皮革软包。



Jobs President Desk

Piano e "Guest area" in Pelle Frau® SC 28 Seppia. Mobile in Rovere Piombo.

Top and "Guest area" in Pelle Frau® leather SC 28 Seppia. Lead Oak Cabinet.

Pelle Frau® SC 28 Seppia (ベッレフラウ® SC 28 セビア)の作業台と"Guest area" (ゲストエリア)。Piombo (鉛色)のオーク製家具。

桌子台面和会客区块采用 Pelle Frau® SC 28 Seppia 皮革,柜体采用铅色橡木饰面。

Piano in Pelle Frau® SC 28 Seppia. "Guest area" e mobile in Rovere Piombo.

Top in Pelle Frau® leather SC 28 Seppia. "Guest area" and cabinet in Lead Oakwood.

Pelle Frau® SC 28 Seppia (ベッレフラウ® SC 28 セビア)の作業台。Piomboのオーク製"Guest area"と引き出しの筐体。

桌子台面采用 Pelle Frau® SC 28 Seppia 皮革, 会客区块和柜体采用橡木。

Il mobile può essere montato a destra o a sinistra della scrivania rispetto alla posizione del fruitore determinandone il verso.

The cabinet can be assembled to the right or left of the desk, based on the user's preference

引き出しの筐体は、利用者の位置から見てデスクの左右どちらかに方向を決めて設置します

柜体可以根据客户需求组装在左侧和右侧。



Jobs President Desk Large

Piano e "Guest area" in Pelle Frau® SC 28 Seppia. Mobile in Rovere Piombo.

Top and "Guest area" in Pelle Frau® leather SC 28 Seppia. Lead Oakwood Cabinet.

Pelle Frau® SC 28 Seppia (ベッレフラウ® SC 28 セビア)の作業台と"Guest area" (ゲストエリア)。Piombo (鉛色)のオーク製引き出しの筐体。

桌子台面和会客区块采用 Pelle Frau® SC 28 Seppia 皮革,柜体采用铅色橡木饰面。

Piano in Pelle Frau® SC 28 Seppia. "Guest area" e mobile in Rovere Piombo.

Top in Pelle Frau® leather SC 28 Seppia. "Guest area" and cabinet in Lead Oakwood.

Pelle Frau® SC 28 Seppia (ベッレフラウ® SC 28 セビア)の作業台。Piomboのオーク製"Guest area"と引き出しの筐体。

桌子台面采用 Pelle Frau® SC 28 Seppia 皮革, 会客区块和柜体采用橡木。

Il mobile può essere montato a destra o a sinistra della scrivania rispetto alla posizione del fruitore determinandone il verso.

The cabinet can be assembled to the right or left of the desk, based on the user's preference.

引き出しの筐体は、利用者の位置から見てデスクの左右どちらかに方向を決めて設置します。

柜体可以根据客户需求组装在左侧和右侧。



Jobs Executive Desk

Piano e "Guest area" in Pelle Frau® SC 80 Bruno Havana.

Top and "Guest area" in Pelle Frau® leather SC 80 Bruno Havana.

Pelle Frau® SC 80 Bruno Havana (ペッレフラウ® SC 80 / Vバナブラウン)の作業台と"Guest area" (ゲストエリア)。

桌子台面和会客区块采用 Pelle Frau® SC 80 Bruno Havana 皮革,柜体采用铅色橡木饰面。



Piano in Pelle Frau® SC 80 Bruno Havana. "Guest area" in Rovere Tabacco.

Top in Pelle Frau® leather SC 80 Bruno Havana. "Guest area" in Tobacco Oak.

Pelle Frau® SC 80 Bruno Havana (ペッレフラウ® SC 80 / Vバナブラウン)の作業台。"Guest area" は Tabacco (黄褐色)のオーク。

桌子台面采用 Pelle Frau® SC 80 Bruno Havana 皮革, 会客区块和柜体采用橡木。



La colonna passacavi è in Rovere Tabacco lucido e può essere montata a destra o a sinistra della scrivania rispetto alla posizione del fruitore.

The cable management column is in polished Tobacco Oakwood and can be assembled to the right or left of the desk in relation to the position of the user.

ケーブルモールはポリッシュ加工を施した Tabacco のオークで、利用者から見てデスクの左右どちらにでも設置できます。

柜体可以根据客户需求组装在左侧和右侧。



Jobs Executive Desk Large

Piano e "Guest area" in Pelle Frau® SC 80 Bruno Havana.

Top and "Guest area" in Pelle Frau® leather SC 80 Bruno Havana.

Pelle Frau® SC 80 Bruno Havana (ペッレフラウ® SC 80 / Vバナブラウン)の作業台と"Guest area" (ゲストエリア)。

桌子台面和会客区块采用 Pelle Frau® SC 80 Bruno Havana 皮革,柜体采用铅色橡木饰面。



Piano in Pelle Frau® SC 80 Bruno Havana. "Guest area" in Rovere Tabacco.

Top in Pelle Frau® leather SC 80 Bruno Havana. "Guest area" in Tobacco Oakwood.

Pelle Frau® SC 80 Bruno Havana (ペッレフラウ® SC 80 / Vバナブラウン)の作業台。"Guest area" は Tabacco (黄褐色)のオーク。

桌子台面采用 Pelle Frau® SC 80 Bruno Havana 皮革, 会客区块和柜体采用橡木。



La cassettera è sempre posizionata sul lato opposto alla colonna passacavi.

The chest of drawers is always positioned on the opposite side to the cable management column.

引き出しは常にケーブルモールの反対側に設置。

柜体可以根据客户需求组装在左侧和右侧。



Jobs Executive with Meeting Area

Piano e "Guest area" in Pelle Frau® SC 80 Bruno Havana. "Meeting area" in Rovere Tabacco.

Top and "Guest area" in Pelle Frau® leather SC 80 Bruno Havana. "Meeting area" in Tobacco Oakwood.

Pelle Frau® SC 80 Bruno Havana (ペッレフラウ® SC 80 / ヴァナブラウン)の作業台と"Guest area" ゲストエリア)。
"Meeting area" (ミーティングエリア)は、Tabacco (黄褐色)のオーク。

桌子台面和会客区块采用 Pelle Frau® SC 80 Bruno Havana 皮革, 会议区块采用烟草色橡木饰面。



Jobs Easy Desk with Meeting Area

La "Meeting area" può essere installata esclusivamente sul lato dove è presente la colonna passacavi.

The "Meeting area" can only be installed on the side of the cable management column.

"Meeting area" (ミーティングエリア)はケーブルモール側のみ設置可能。

会议区块只可以安装在电缆管理管道侧面。

La colonna passacavi è in Rovere Tabacco lucido.

The cable management column is in polished Tobacco Oakwood.

ケーブルモールは、ポリッシュ加工を施した Tabacco (黄褐色)のオーク製。

电缆管理管道采用亮光烟草色橡木饰面。



Jobs Easy Desk

Piano e "Guest area" in Pelle Frau® SC 80 Bruno Havana.

Top and "Guest area" in Pelle Frau® leather SC 80 Bruno Havana.

Pelle Frau® SC 80 Bruno Havana (ペッレ Frau® SC 80 ハバナブラウン)の作業台と "Guest area" (ゲストエリア)。

桌子台面和会客区块采用 Pelle Frau® SC 80 Bruno Havana 皮革。



Piano in Pelle Frau® SC 80 Bruno Havana. "Guest area" in Rovere Tabacco.

Top in Pelle Frau® leather SC 80 Bruno Havana. "Guest area" in Tobacco Oakwood.

Pelle Frau® SC 80 Bruno Havana (ペッレ Frau® SC 80 ハバナブラウン)の作業台。"Guest area" は、Tabacco (黄褐色)のオーク製。

桌子台面采用 Pelle Frau® SC 80 Bruno Havana 皮革，会客区块采用烟草色橡木饰面。



Colonna passacavi in Rovere Tabacco lucido.

The cable management column is in polished Tobacco Oakwood.

ケーブルモールドは、ポリッシュ加工を施した Tabacco のオーク製。

电缆管理管道采用亮光烟草色橡木饰面。



Jobs Easy Desk Large

Piano e "Guest area" in Pelle Frau® SC 80 Bruno Havana.

Top and "Guest area" in Pelle Frau® leather SC 80 Bruno Havana.

Pelle Frau® SC 80 Bruno Havana (ペッレ Frau® SC 80 ハバナブラウン)の作業台と "Guest area" (ゲストエリア)。

桌子台面和会客区块采用 Pelle Frau® SC 80 Bruno Havana 皮革。



Piano in Pelle Frau® SC 80 Bruno Havana. "Guest area" in Rovere Tabacco.

Top in Pelle Frau® leather SC 80 Bruno Havana. "Guest area" in Tobacco Oakwood.

Pelle Frau® SC 80 Bruno Havana (ペッレ Frau® SC 80 ハバナブラウン)の作業台。"Guest area" は、Tabacco (黄褐色)のオーク製。

桌子台面采用 Pelle Frau® SC 80 Bruno Havana 皮革，会客区块采用烟草色橡木饰面。



La colonna passacavi può essere montata a destra o a sinistra della scrivania rispetto alla posizione del fruitore.

The cable management column can be assembled to the right or left of the desk in relation to the position of the user.

ケーブルモールドは利用者から見てデスクの左右どちらにでも設置できます。

电缆管理管道可以根据用户需求安装在左边或者右边。



Jobs

L283 / L227

Top in Rovere Piombo lucido.

Lead Oakwood top with polished finish.

上部はポリッシュ加工を施した Piombo (鉛色) のオーク製。

桌子台面采用亮光铅色橡木饰面。



Il rivestimento frontale dei cassetti e dell'anta è in Pelle Frau® SC 28 Seppia.

Drawer fronts upholstered in Pelle Frau® leather SC 28 Seppia.

引き出しと扉の上張りは Pelle Frau® SC 28 Seppia (ペッレフラウ® SC 28 セビア) 製。

抽屉面板采用 Pelle Frau® SC 28 Seppia 皮革软包。



Jobs

Drawer Unit

Top in Rovere Piombo opaco.

Lead Oakwood top with matte finish.

上部はマット加工を施した Piombo (鉛色) のオーク製。

桌子台面采用哑光铅色橡木饰面。



Frontali in Pelle Frau® SC 28 Seppia.

Fronts in Pelle Frau® leather SC 28 Seppia.

正面は Pelle Frau® SC 28 Seppia (ペッレフラウ® SC 28 セビア) 製。

前面采用 Pelle Frau® SC 28 Seppia 皮革软包。



La base è verniciata nero testurizzato antigraffio e dotata di 4 ruote piroettanti

The base is painted black with a textured scratch-resistant finish and has four castors.

台はアンチスクラッチ加工とテクスチャー加工を施したブラックカラーで、4つのキャスター付き。

底座采用黑色纹理防划饰面，带四个脚轮。



Vano interno al piano di lavoro corredato di vassoio portapenne e equipaggiato centralmente con un dispositivo di elettrificazione da acquistare separatamente.

作業台内部の空間には、ペン置き用のトレーが備えられ、中心には別途販売されている電化装置を装備できます。

Inner compartment of the work surface complete with pen tray and equipped with a central electrification device that is purchased separately.

工作区块的内部隔断可以放置钢笔托盘，安装充电插口，需要单独采购。

Jobs President Desk — Dettaglio tecnico del passaggio cavi — Technical details of the cable passage — ケーブル配線に関する技術的詳細 — 电缆管道的技术细节

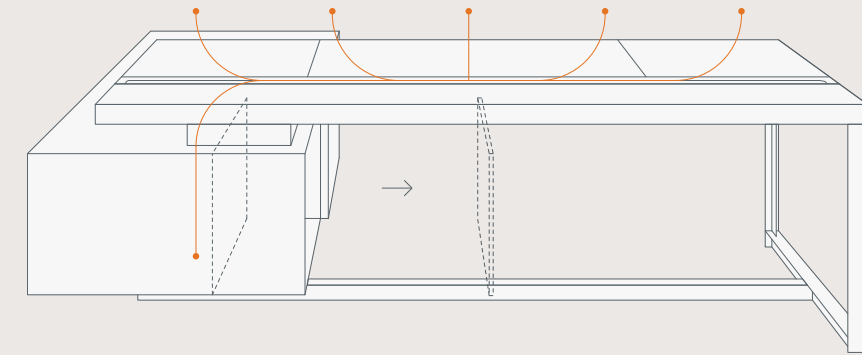

Jobs Executive Desk — Dettaglio tecnico del passaggio cavi — Technical details of the cable passage — ケーブル配線に関する技術的詳細 — 电缆管道的技术细节

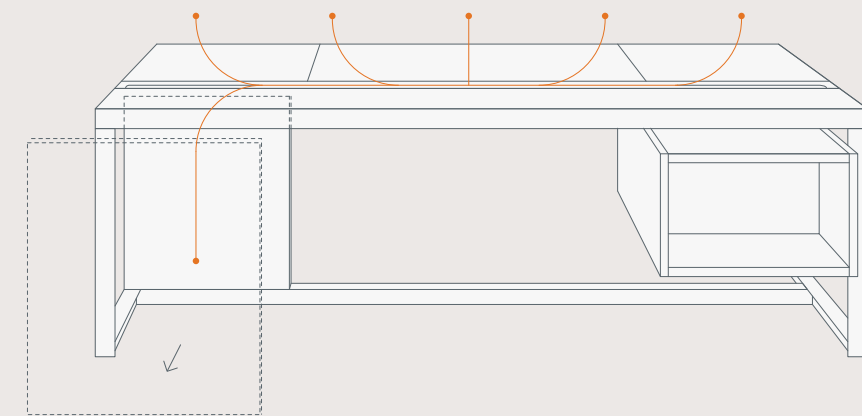

Jobs President Desk — “Guest area” in Pelle Frau® SC

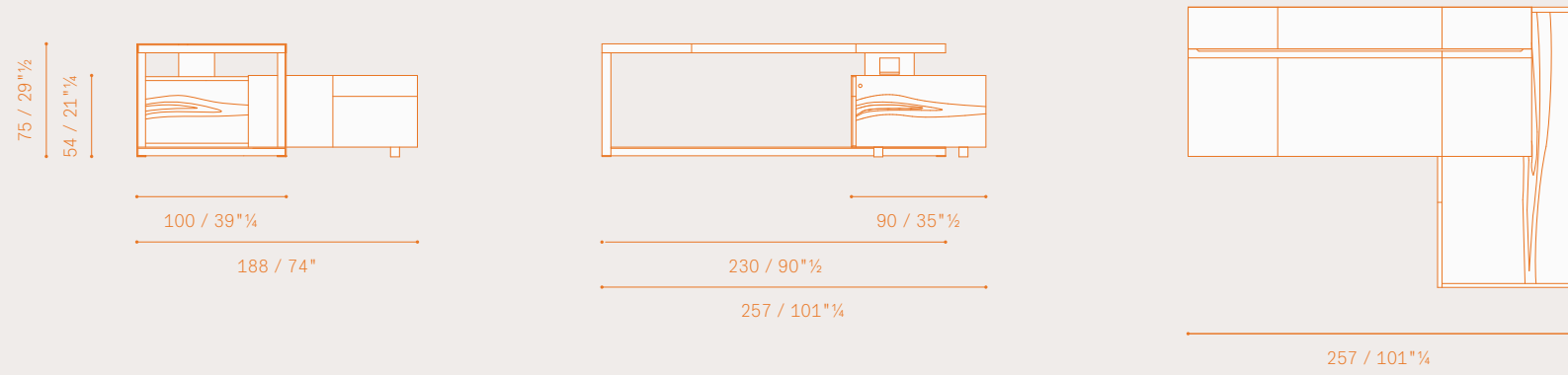

Jobs President Desk — “Guest area” in Oakwood

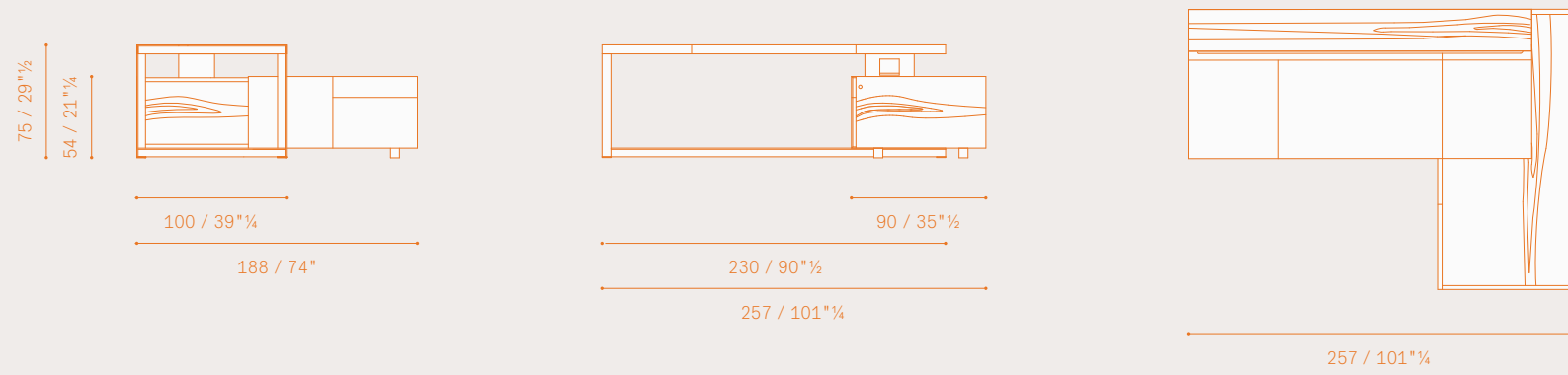

Jobs President Desk Large — “Guest area” in Pelle Frau® SC

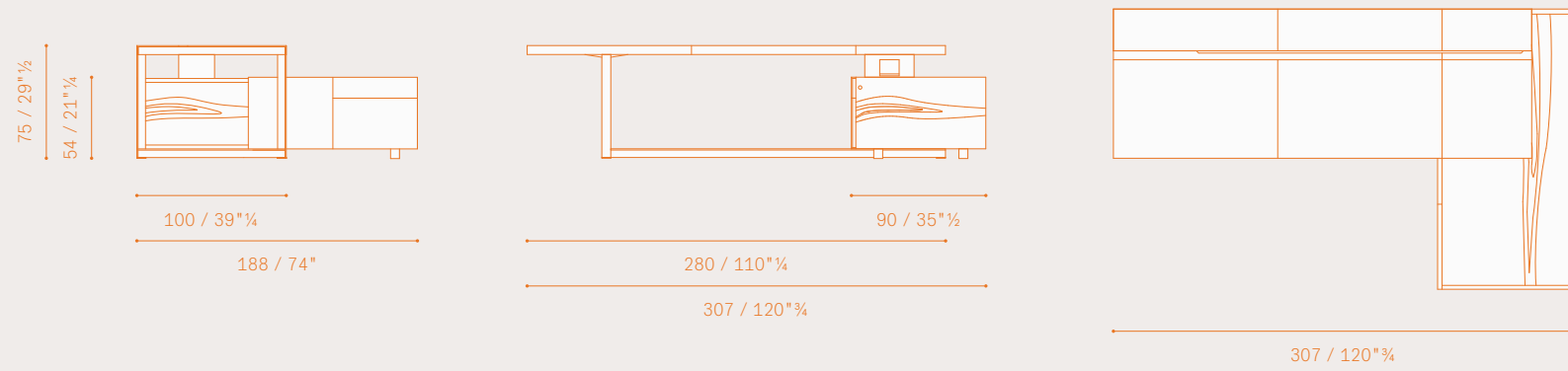

Jobs President Desk Large — “Guest area” in Oakwood

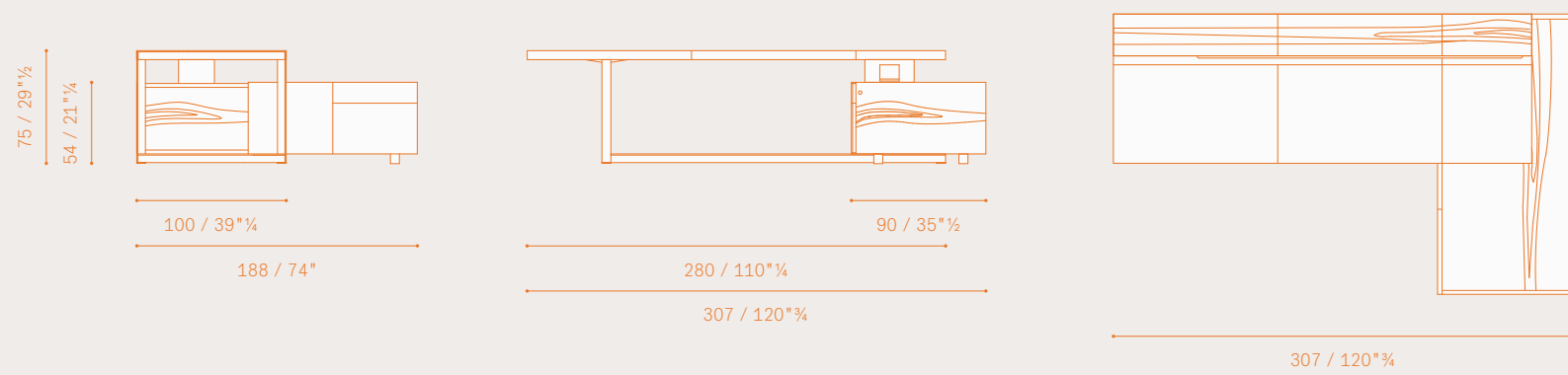

Jobs Executive Desk — “Guest area” in Pelle Frau® SC

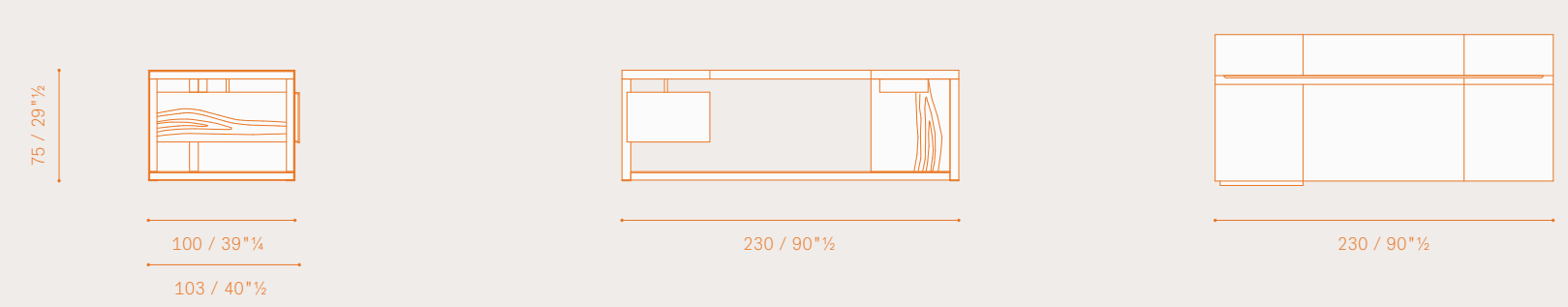

Jobs Executive Desk — “Guest area” in Oakwood

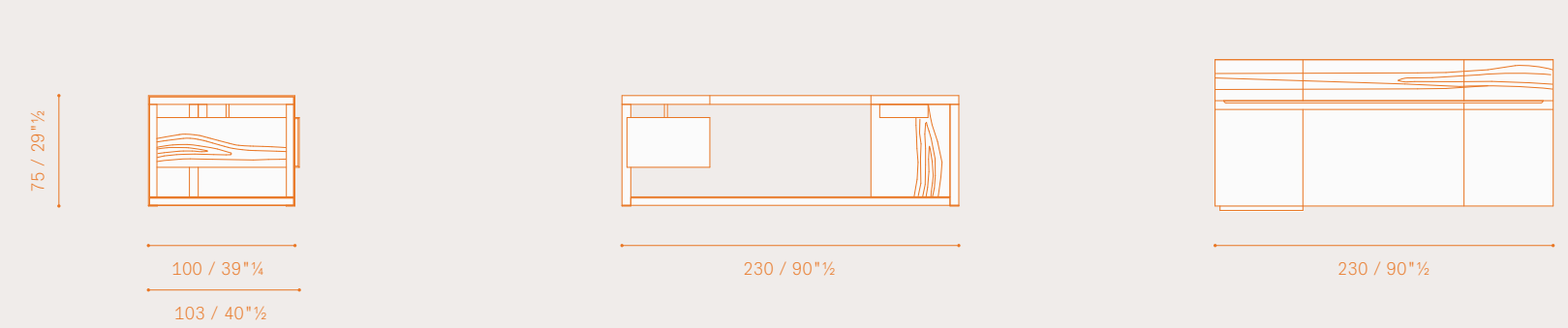

Jobs Executive Desk Large — “Guest area” in Pelle Frau® SC

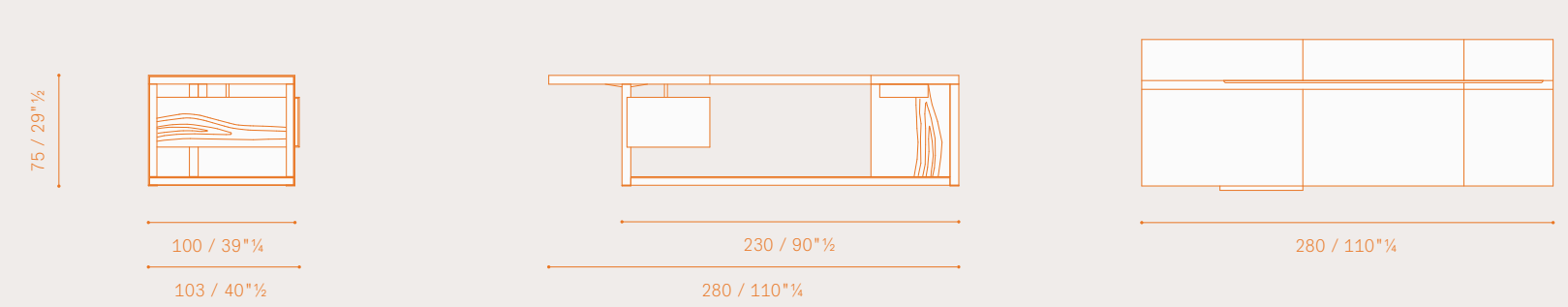

Jobs Executive Desk Large — “Guest area” in Oakwood

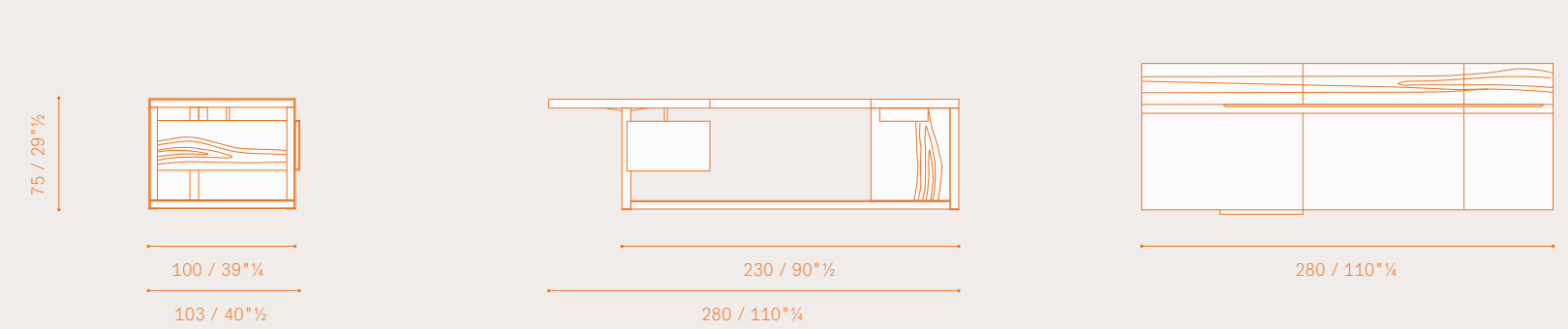

Jobs Executive Desk with "Meeting area" — "Guest area" in Pelle Frau® SC

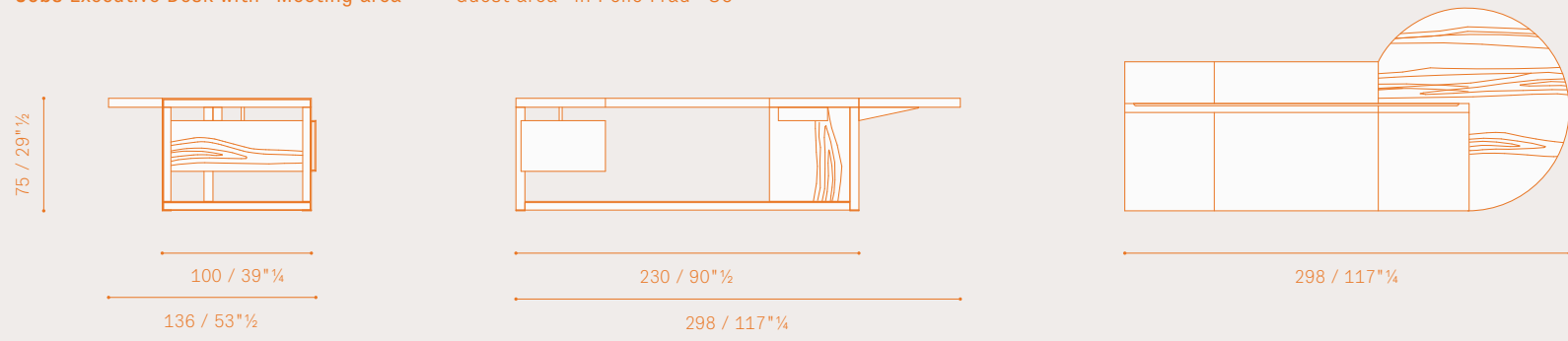

Jobs Executive Desk with "Meeting area" — "Guest area" in Oakwood

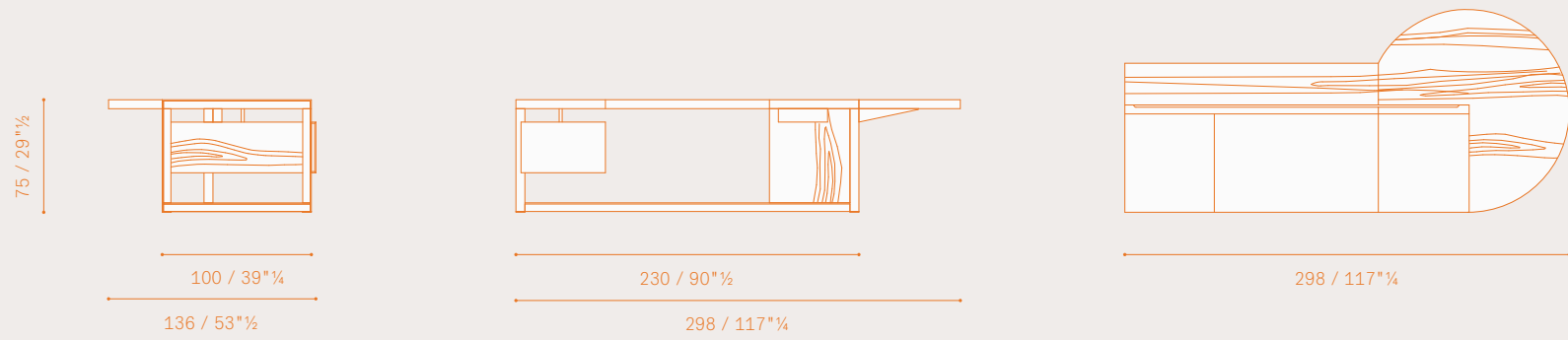

Jobs Easy Desk — "Guest area" in Pelle Frau® SC

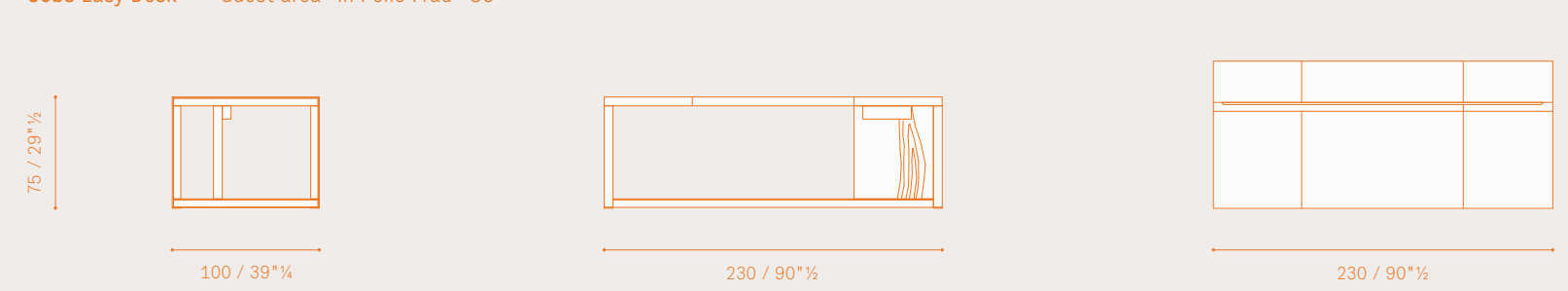

Jobs Easy Desk — "Guest area" in Oakwood

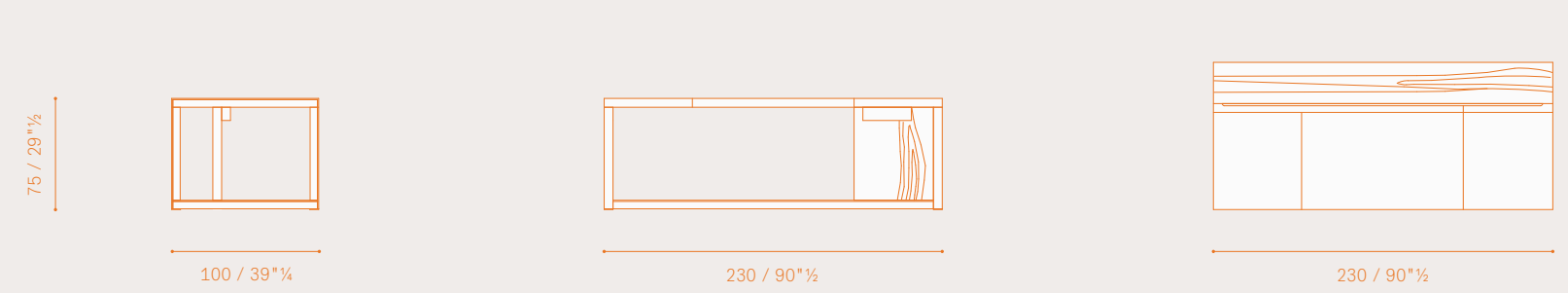

Jobs Easy Desk Large with "Meeting area" — "Guest area" in Pelle Frau® SC

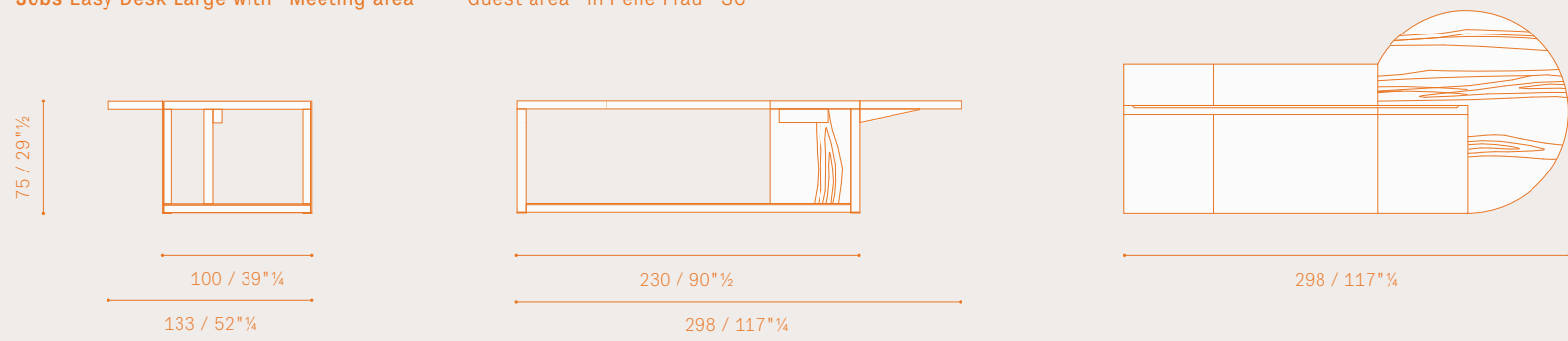

Jobs Easy Desk Large with "Meeting area" — "Guest area" in Oakwood

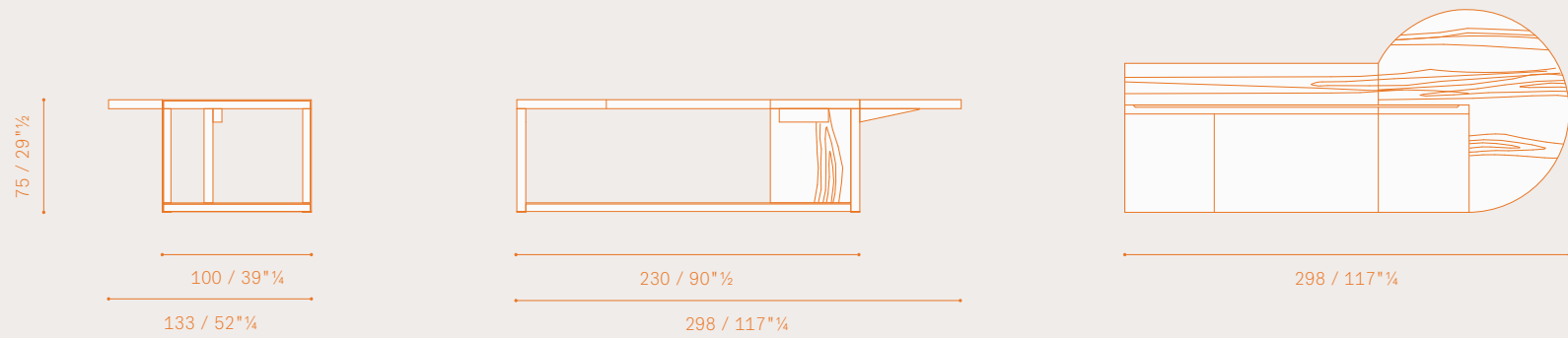

Jobs Easy Desk Large — "Guest area" in Pelle Frau® SC

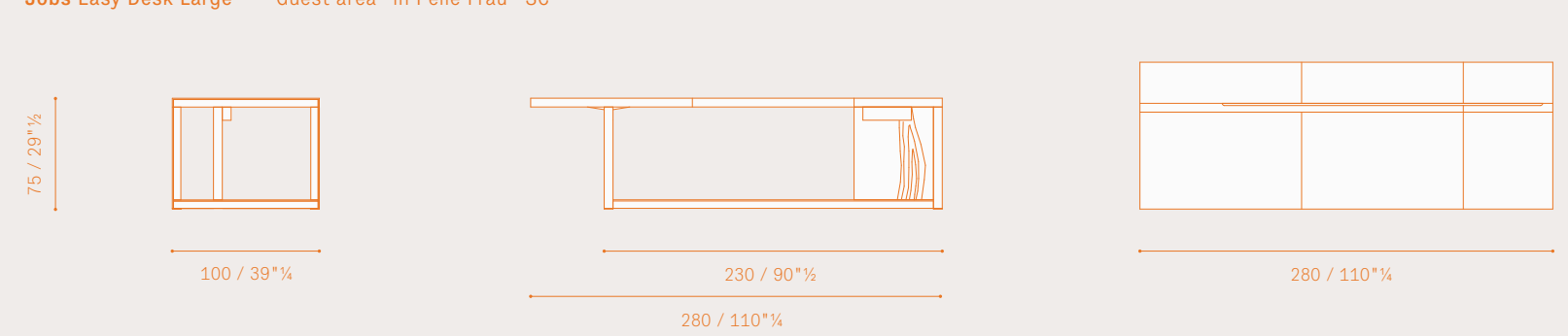

Jobs Easy Desk Large — "Guest area" in Oakwood

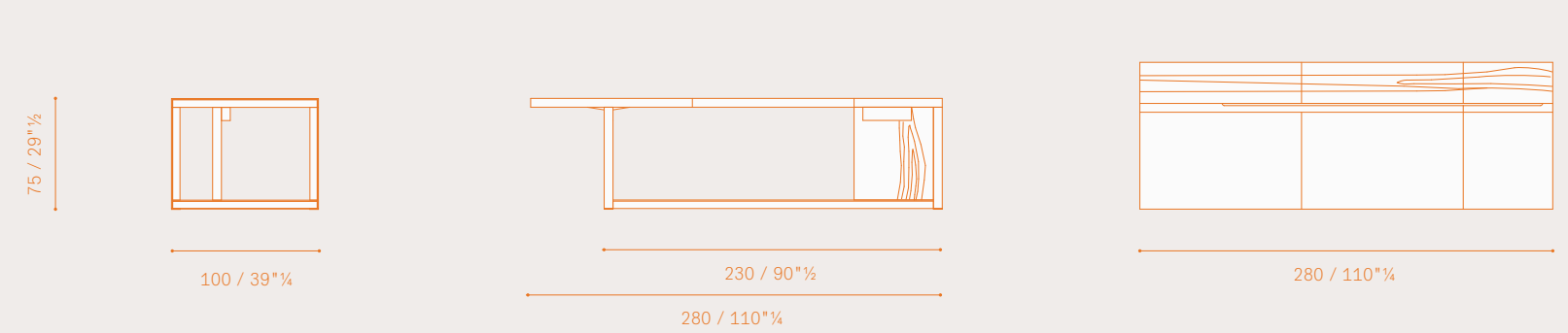

Jobs Low Cabinet 284 cm — 2 drawers and 2 filing cabinets and 1 compartment door

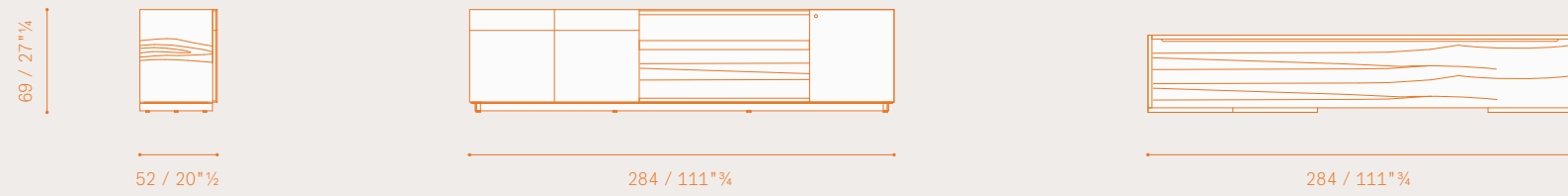

Jobs Low Cabinet 284 cm — 3 compartments door

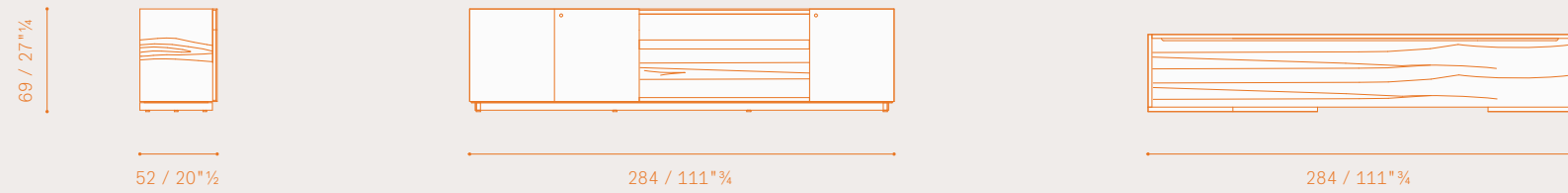

Jobs Low Cabinet 230 cm — 2 drawers and 2 filing cabinets

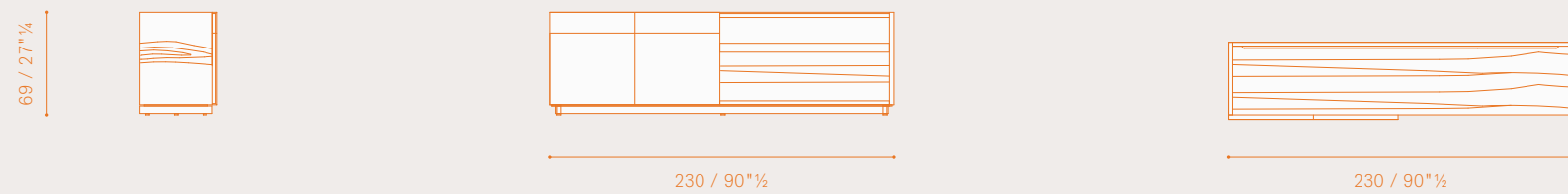

Jobs Low Cabinet 230 cm — 2 compartments door

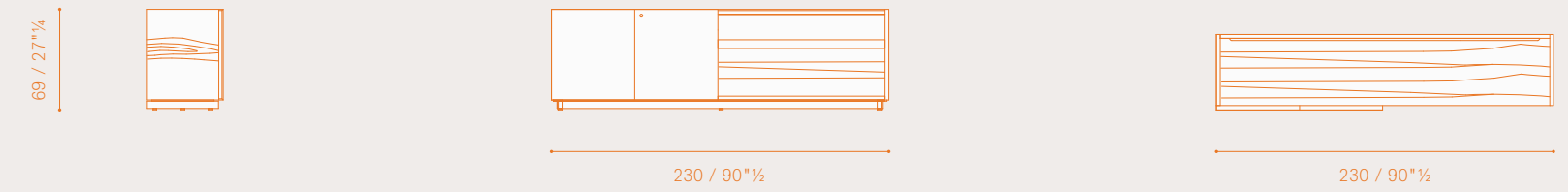

Jobs Drawer Unit

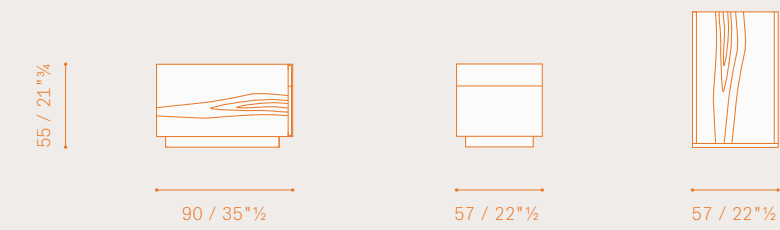

Jobs — Finishings

Desk top and front panels
Pelle Frau® leather from the Color System

Structure
Brushed steel with a lead painted finish

Column, structure and wood details
— Lead Oakwood
— Tobacco Oakwood

“Guest Area”
— Pelle Frau® leather from the Color System
— Lead Oakwood
— Tobacco Oakwood

Jean-Marie Massaud

DownTown

JEAN-MARIE MASSAUD

Laureato all'ENSCI nel 1990, Jean-Marie Massaud è fin da subito alla ricerca di sintesi, riduzione e leggerezza. Affronta i diversi aspetti del design: dai mobili ai prodotti industriali, alle attrezzature. Nel 2000, crea lo Studio Massaud ed estende la sua attività all'architettura e alle strategie di sviluppo. Ponendo l'uomo ed il suo ambiente naturale al cuore delle sue creazioni, questo ideatore senza limiti adotta un modo di procedere impegnato e politico e si sforza di trasformare ogni progetto in un'esperienza di vita e in uno scenario economico che riconcilia desiderio e responsabilità.

CONCEPT

Competente, elegante, senza tempo... DownTown è la poltrona da lavoro dedicata a "decision-makers" esigenti che ricercano comfort e eleganza raffinata. Una seduta tecnica che si rivela una silhouette, fatta a mano dagli artigiani di Poltrona Frau come garanzia di alta qualità. Molto più di una bella scultura, DownTown è una creazione sensuale e distintiva di Jean-Marie Massaud.

JEAN-MARIE MASSAUD

Jean-Marie Massaud graduated from ENSCI (the French national school for advanced studies in design) in 1990 and from the very outset he has sought synthesis, essentiality and lightness. He has handled all aspects of design, from furniture to industrial products and equipment. In 2000, he founded Studio Massaud and expanded his expertise to architecture and brand development. By placing humanity and the natural environment at the heart of his creations, this free-thinking designer adopts an engaged and political approach, striving to make every project into a life experience and to do so within an economic framework that reconciles desire and responsibility.

CONCEPT

Proficient, elegant, and timeless... DownTown is a desk armchair specially dedicated to demanding decision-makers who seek comfort and refined elegance. A technical seat that looks like a silhouette; handcrafted by Poltrona Frau as a guarantee of the highest quality. More than a beautiful sculpture, DownTown is a sensual and distinctive creation by Jean-Marie Massaud.

ジャン・マリー・マッソー

1990年にENSCIを卒業してすぐに、Jean-Marie Massaudは、合成と縮小そして軽さの研究を始め、家具から工業製品や機材におけるまで、デザインの(多様な側面)多面性の考察を行う。2000年には、Studio Massaud (マッソー・スタジオ)を設立し、建築や開発計画にまで活動の拡大。創造の中心に人間と自然環境というテーマを想定し、その限界を持たない考案者は積極的かつ政治的な工程を進め

る方法を選びつつ、あらゆるプロジェクトを人生の経験として、また欲望と責任感を折衷する経済的なシナリオとして、形を変える努力をしている。

コンセプト

卓越していて、優雅で、時間効果なしには。DownTownは、快適性と洗練された優雅さを求める、要求の多い"decision-makers" デジジョン マーカーのために仕事用アームチェアです。技術的に座ってもまるでシルエットの様で、職人の手作業 手作りから生まれる Poltrona Frau (ポルトローナ・フラウ)の品質の高さを証明しています。DownTownは、美しい彫刻以上のもの、Jean-Marie Massaudによる官能的で比類のない被造創造的物なのです。

让·马利·马沙德

让·马利·马沙德 1990年毕业于ENSCI(法国高级设计学校)后,立即致力于综合化、精简化和轻巧化的研究之中。他的设计涉及各个领域:从家具到工业产品,再到设备。2000年创建了马沙德事务所并拓展了其建筑及品牌拓展的业务。以人和自然环境为创意的核心,设计师采取合理的方式将每个项目转变为人生的体验,并在理想的框架下调和需求和责任。

理念

干练、优雅、经久耐用... DownTown是专为寻求舒适、典雅、细腻的决策者而设计的办公椅。专业的办公椅看起来像一件艺术品,由Poltrona Frau的工匠手工制作,是高品质的保证。但又不仅仅作为一个艺术品,DownTown也是让·马利·马沙德 Jean-Marie Massaud的一个情感上的独特创造。



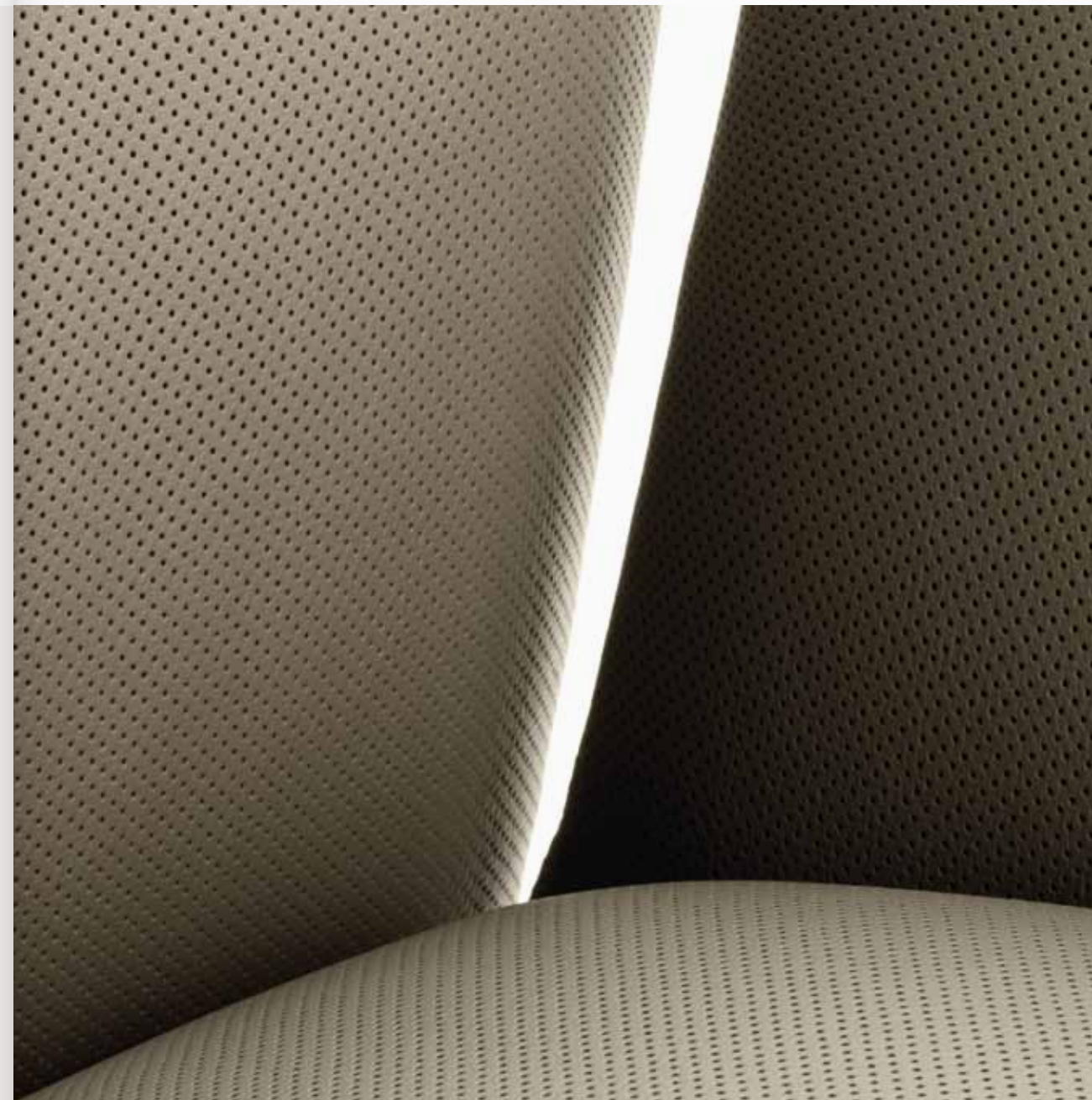

La superficie interna della seduta è in Pelle Frau® del Color System, qui in versione microforata SC 51 Panna.

座面内部のカバーは、Pelle Frau® ベッレ Frau® カラーシステムで、SC 51 Panna のマイクロドット版です。

The inner surface of the seat is in Pelle Frau® leather from the Color System, here in the micro-perforated SC 51 Panna version.

座椅の内側使用 Pelle Frau® 皮革系列，这里为 SC 51 Panna 皮革。

DownTown President / Executive / Visitor



DownTown President — Castors or glides



DownTown Executive — Castors or glides

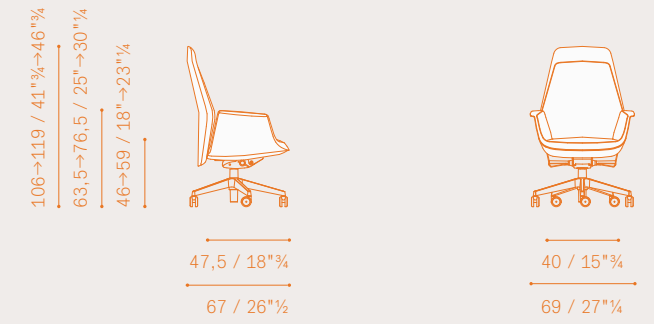

DownTown Managerial — Castors or glides



DownTown Meeting — Castors or glides

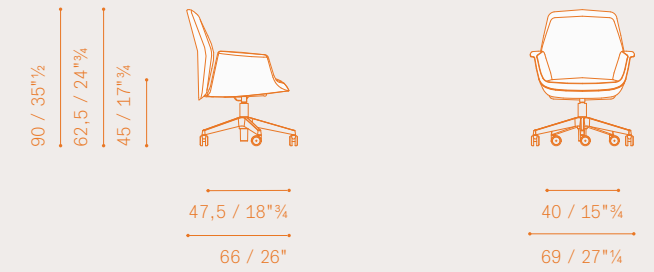

DownTown — Finishings

- Upholstery**
- Pelle Frau® leather from the Color System
 - Micro-perforated Pelle Frau® leather from the Color System

- Base**
- Aluminium in a black finish
 - Polished aluminium

DownTown Visitor — Glides

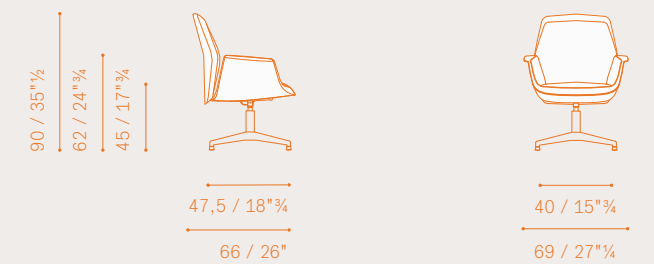

Roberto Lazzeroni

Ginger Ale Office



ROBERTO LAZZERONI

Nato a Pisa, Roberto Lazzeroni compie un percorso professionale dinamico legato agli studi di Arte e Architettura compiuti a Firenze e agli interessi maturati, negli anni della sua formazione, verso i fenomeni dell'arte concettuale e del Radical Design. Debutta all'inizio degli anni '80 con una serie di importanti lavori di "Architettura d'Interni", subito notati e pubblicati da riviste italiane ed estere. Impegnato su diversi fronti con collaborazioni prestigiose, art direction e progetti d'interni e contract in varie parti del mondo, annovera importanti riconoscimenti internazionali.

CONCEPT

Ginger Ale Office riprende l'iconica scocca a guscio con le due aperture laterali a goccia tipiche di Ginger e Ginger Ale, ampliandone ulteriormente le possibilità d'uso. Fresca, ben disegnata, modernissima nelle sue varianti, si presta con versatilità sia agli spazi di lavoro, come seduta per singole postazioni o sale riunioni, che agli spazi pubblici o alla zona studio/lavoro di casa.

生命伝記

ピサ生まれ。Roberto Lazzeroni (ロベルト・ラッツオーニ)は、フィレンツェで勉強した美術・建築と彼が長年興味を持っていたコンセプチュアル・アートと Radical Design (ラディカル・デザイン)の現象を結び付けながら、精力的に仕事を積み重ねてきました。80年代初頭に、一連の "Architettura d'Interni" (インテリア建築)の重要な作品でデビューし、即座に注目されたイタリア内外の雑誌に掲載

され話題になりました。また、一流の世界でのコラボレーションやアートディレクション、内装設計や世界各国からのコントラクトなど多分にで積極的に活動を行い、世界的に高い知名度を得ています。

コンセプト

Ginger Ale Office (ジンジャー・エール・オフィス)では、ジンジャーとジンジャー・エールの特徴である一滴のしずくの形をした二つの穴を両脇に空けたシェルがその椅子の本領になっていますが、このデザインがさらに使い勝手の幅を広げています。新鮮で、良質なデザイン、バラエティーに富んでいて現代的なこのアームチェアは、個人使用、または会議など仕事の場、かつ公共の場所や勉強・家事のスペースにも合うなど大変多才です。

ROBERTO LAZZERONI

Pisa-born Roberto Lazzeroni has enjoyed a dynamic career path very much linked to his art and architecture studies in Florence and the interest he acquired, while studying, in the phenomena of conceptual art and Radical Design. He made his debut in the early 1980s with a series of important "Interior Design" works, which were immediately noticed and published by national and international magazines. He has been engaged on several fronts with prestigious collaborations, art direction and interior design and contract projects in various parts of the world, and has won major international awards.

CONCEPT

Ginger Ale Office takes the iconic shell with the two lateral drop-shaped openings typical of Ginger and Ginger Ale and further expands their possible use. Fresh, well-designed, and highly modern with a number of variants, it lends versatility to work spaces, as a seat for individual workstations or meeting rooms, and to public spaces or study and work areas in the home.

罗伯特·拉泽罗尼

出生于比萨，在佛罗伦萨出色地完成了建筑学及艺术学的专业学习，在学习的那几年里，获得了浓厚的概念艺术和激进设计现象的兴趣。自八十年代初的一系列重要的“室内设计”作品而初露头角，之后立即引起了意大利及国外杂志的注意并公开发表其作品。其在世界各地均有签约并从事于室内项目、艺术指导、高端合作等前沿工作，从而在国际上被熟知。

理念

Ginger Ale 办公椅采用并延展了 Ginger 和 Ginger Ale 座椅的合理使用，侧面水滴形开口的标志性外型依然是其特点。清新、巧妙设计、多变并极富现代感，用途广泛，可以是独立的工作区，也可以出现在会议室，满足公共空间或家庭学习工作区域的多功能性。

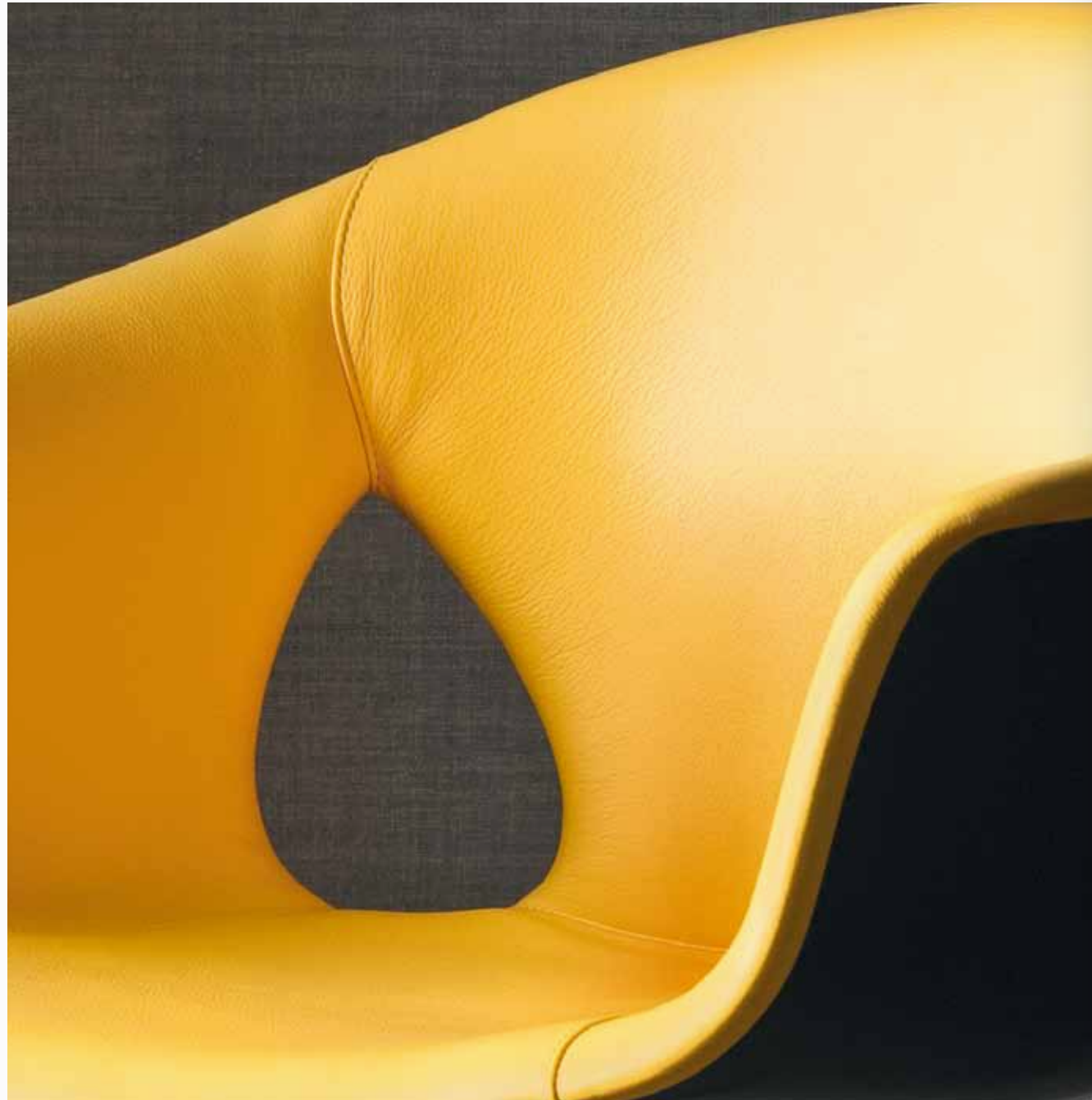

La scocca esterna è disponibile nei colori "gesso" e "antracite". Rivestimento interno in Pelle Frau® del Color System 143 Carioca.

The outer shell comes in "chalk" and "anthracite". It is upholstered in Pelle Frau® leather from the Color System 143 Carioca.

外側本体は、「gesso」(石膏色)と「antracite」(艶のある薄墨色)の2色。インナー・カバーは Pelle Frau® ペッレフラウ®カラーシステム 143 カリオカ。

座椅外壳可以使用“石膏”色或“炭黑”色。座椅内侧采用 Pelle Frau® 皮革系列的 143 号色 Carioca。





Ginger Ale Office

Poltrona con base a 5 razze
(altezza fissa o regolabile)

Armchair with 5-spoke base
(fixed or adjustment height)

5 スポーク・ベース付きアームチェア
(高さ固定もしくは可動式)

5 星滚轮单椅 (固定高度或高度可调)



Poltrona con base a 4 razze

Armchair with 4-spoke base

4 スポーク・ベース付きアームチェア

4 星轮辐单椅



Poltrona con colonna a 4 razze
(fissa o girevole)

Armchair with 4-spoke column base
(fixed or swivel)

4 スポーク・コントラクト・ベース付きアームチェア (固定もしくは回転式)

4 腿扶椅 (固定或可旋转)



Ginger Ale Office — Armchair with 5-spoke base and fixed-height

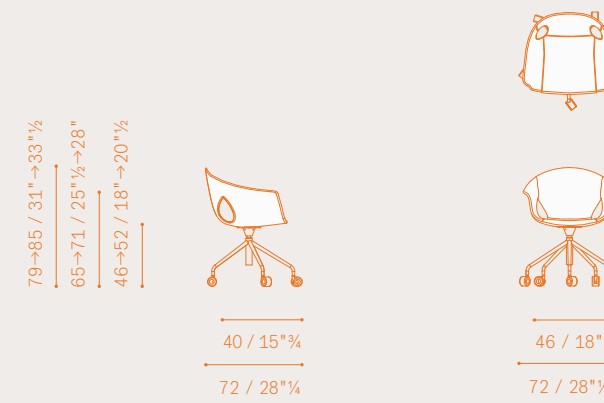

Ginger Ale Office — Armchair with 5-spoke base and height-adjustment

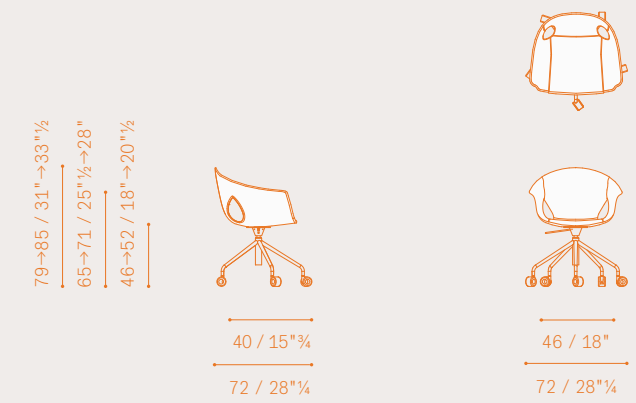

Ginger Ale Office — Fixed armchair with 4-spoke column base

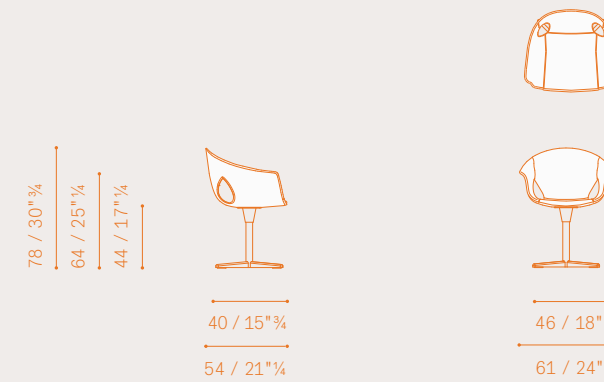

Ginger Ale Office — Swivel Armchair with 4-spoke column base

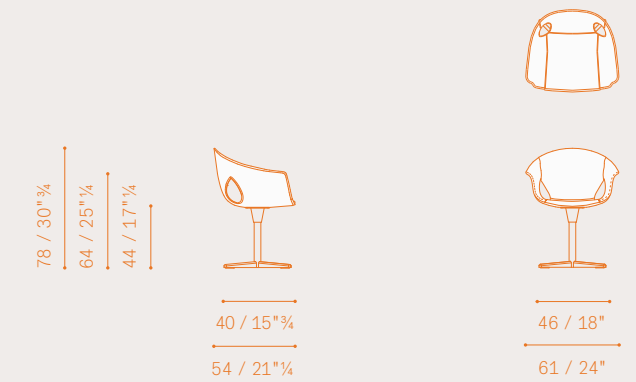

Ginger Ale Office — Finishings

Upholstery

— Pelle Frau® leather from the Color System

External frame finish

— "chalk" color
— "Anthracite" color

Base finish

— "chalk" color
— "Anthracite" color
— Chrome finished metal

Ginger Ale Office — Armchair with 4-spoke base

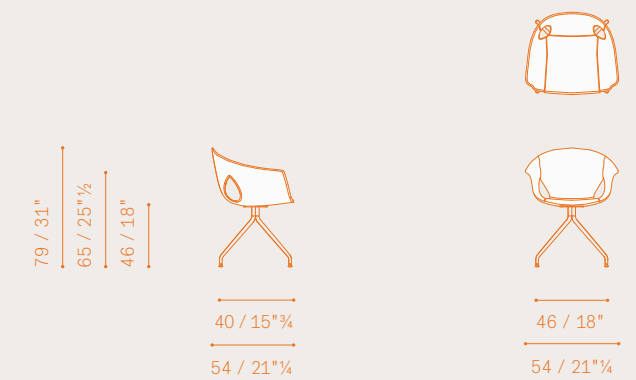

Pelle Frau® Color System Frau®

PELLE FRAU®

Ingrediente principe del suo successo, la pelle rappresenta per Poltrona Frau molto più di una semplice materia di progetto: pelle e cuoio sono "icone materiali" da utilizzare in quanto simbolo di eleganza, prestigio, qualità. Per dare alla pelle un volto attuale, Poltrona Frau ha sviluppato nel tempo processi esclusivi di lavorazione delle pelli bovine. Solo pelli in grado di garantire caratteristiche di impermeabilità, traspirazione, resistenza allo sfregamento e alle macchie, vengono definite Pelle Frau®.

PELLE FRAU® LEATHER

Leather is much more than a valuable design material for Poltrona Frau: a key ingredient in its success, leather is perceived as a veritable "icon", a material symbolizing elegance, prestige and quality. To give the leather an up-to-date image, over the years Poltrona Frau has developed exclusive techniques for the treatment of calf skins that ensure excellent properties in terms of impermeability, breathability, resistance to rubbing and stains are deemed eligible to go by the name of Pelle Frau® Leather.

COLOR SYSTEM FRAU®

Pelle Frau® significa anche colore, come le tonalità progettate del Color System: un'ampia varietà di nuance che permette di creare abbinamenti armonici delle tinte sia fra arredi diversi che all'interno dello stesso oggetto. Una particolare ricerca tecnica e la notevole esperienza di Poltrona Frau hanno permesso un ideale equilibrio tra il materiale naturale e il trattamento della superficie in fase di rifinitura. Interessante sotto il profilo organolettico, la Pelle Frau® del Color System con il tempo acquista in eleganza.

Pelle Frau® leather means colour, too, like the planned colours of the Color System: a wide variety of different nuances of colours. This makes it possible to harmoniously combine the shades both among the different pieces of furniture and of the same object. Poltrona Frau's special technical research and considerable experience have allowed to achieve the perfect balance between the natural material and surface treatment in the finishing phase. Interesting in organoleptic terms, for its high-resistance features and for its excellent response during use and care, Pelle Frau® leather of the Color System gains in elegance over time.

PELLE FRAU® ペッレフラウ®

コレクションの成功に重要な役割を果たした素材です。Poltrona Frau ポルトローナ・フラウ社にとって、革は単なるプロジェクトの素材以上の存在、エレガンス、格調、品質を象徴する「究極の素材」といえるでしょう。革に現代的な特徴を与えるために、Poltrona Frau ポルトローナ・フラウ社は時間をかけて独自の牛革加工プロセスを開発してきました。

防水性、通気性、摩擦への耐久性、汚れ難さを兼ね備えた革だけに、Pelle Frau® ペッレフラウ®の称号が許されるのです。

COLOR SYSTEM FRAU® カラーシステムフラウレザー®

カラーシステムフラウレザーのカラーチャートが示す通り、Pelle Frau® ペッレフラウ®の特徴は彩りでもあります。豊富な色彩のニュアンスは他のインテリアとの調和のとれたコーディネートや製品自体の色調の調和を生みます。Poltrona Frau ポルトローナ・フラウ社は特別な技術開発と長年の経験を活かして、革の仕上げの段階で天然皮革に施す表面の加工の理想的なバランスを見出しました。Pelle Frau® ペッレフラウ®のColor System Frau® カラーシステムフラウレザーは、時を重ねるほどそのエレガンスを増して行きます。

PELLE FRAU® 皮革

皮革不仅仅是 Poltrona Frau 所采用的有价值的材料，同时是其成功的关键因素，皮革被公认为一种象征优雅、高贵和品质的材料。为使皮革具有与时俱进的形象，百年来 Poltrona Frau 开发了独特的牛皮处理技术。只有具有 Pelle Frau® 商标的皮革才能保证在渗透性、透气性、耐磨和防污上具有优越的特性。

COLOR SYSTEM FRAU® SC 皮革系列

Pelle Frau® 皮革也意味着色彩，正如 Color System 系列中所展现出的色彩：色彩的细微差别和多样性。这使得在不同的产品乃至于同一个产品上，不同的色调组合都可以达到和谐自然。Poltrona Frau 的特殊工艺研究和现有经验相结合使得天然原材料和表面处理后的饰面之间达到完美的平衡。在持久的皮革特性和使用及保养的优越反馈基础上，在感官上，Pelle Frau® SC皮革时间越久越感到典雅。



2014 Office Collection Credits

CONTACTS

Poltrona Frau S.p.A.
I - 62029 Tolentino
Via S. Pertini 22

Tel. +39 0733 909.1
Fax +39 0733 971600
www.poltronafrau.it
info@poltronafrau.it

CREDITS

Art direction / Graphic design
studio FM milano

Photography
Riccardo Bianchi

Adriano Brusaferrì
(8-9-10-11-12-13-14-15-39-46-47)

Styling
Studio Salaris

Printing
Arti Grafiche Meroni



© POLTRONA FRAU 2014

Company with certified Quality Management System in accordance with ISO 9001,
certified Environmental Management system in accordance with ISO 14001
and certified Occupational Health and Safety Management System in accordance
with BS OHSAS 18001.

